

BILL OF MATERIALS				
NO.	Part Name	Materials	Materials	Notes
6	Bolt	A193 B8	A193 B7	3.
5	Bonnet	A182 F316	A105	2,
4	Gasket	304SS+Graphite	304SS+Graphite	
3	Spring	A276 304	A276 304	4
2	Disc	A182 F316	A276 420	1, 2,
1	Body+Seat*	A182 F316	A105	1, 2,

\*: Seat integral

- Notes:
1. Stellite available – dependant on quotation
  2. (L) low carbon materials available dependant on quotation
  3. NACE (M) bolting available – dependant on quotation
  4. Optional

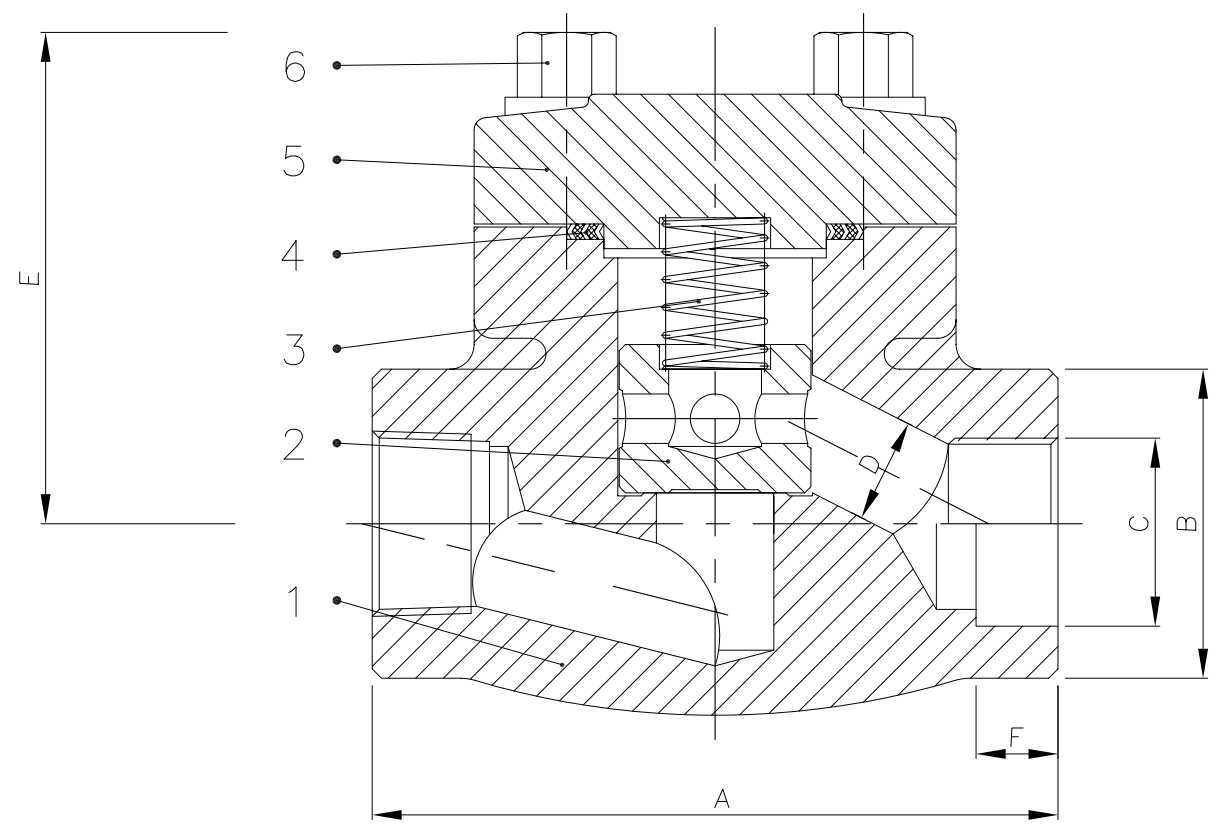

NB	DN	A	B	D	C	E	F	G	Wgt
1/2"	15	79	32	10	21.7	63	10		1.3
3/4"	20	92	38	13	27.1	64	13		1.4
1"	25	111	48	17	33.8	79	14		2.4
1 1/2"	40	152	65	27	48.6	105	14		7.4
2"	50	172	78	33	61.1	124	16		9.0

All drawings are subject to copyright, reproduction only with express permission of Edmund Valve Company (1965) Ltd. Subject to updating and revision. All Edmund valves drawings are product specific, it is the clients responsibility to ensure suitability for service. Materials, design and dimensions subject to contract.

DESIGN CODE	API 602/ANSI B16.34	TEST PRESSURES		
FACE TO FACE DIMENSIONS	ANSI B 16.10	BODY	211.0	Barg
ENDS FLANGES DIMENSIONS	ASME B16.5	SEAT	155.0	Barg
TESTING CODE	API 598	BACKSEAT	155.0	Barg
		AIR - SEAT	6.0	Barg

REV	DATE	DESCRIPTION	BY	CHK	APP	SCALE:		
						DRAWN	DM	DATE: 14/12/10
						CHECKED	SMN	DATE
						APPROVED	AW	DATE

Materials available include: Duplex & Super Duplex  
Monel, Inconel, Chrome-moly

DRAWING TITLE:  
API FORGED, CLASS 800  
BOLTED COVER, SW/NPT, PISTON CHECK VALVES

CLIENT: .

VENDOR PO REF: .

EVC REF: .

CAD. No. DRAWING NUMBER: 120213 REV 00

AREA No. FACILITY TYPE SEQ. No. SHT. No.