

1 | 2 | 3 | 4 | 5 | 6 | 7 | 8

A

B

C

D

E

A

B

C

D

E

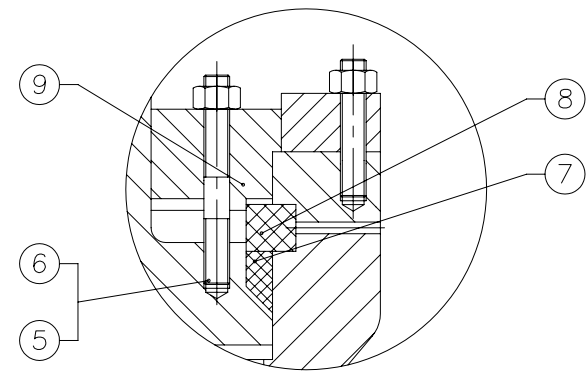
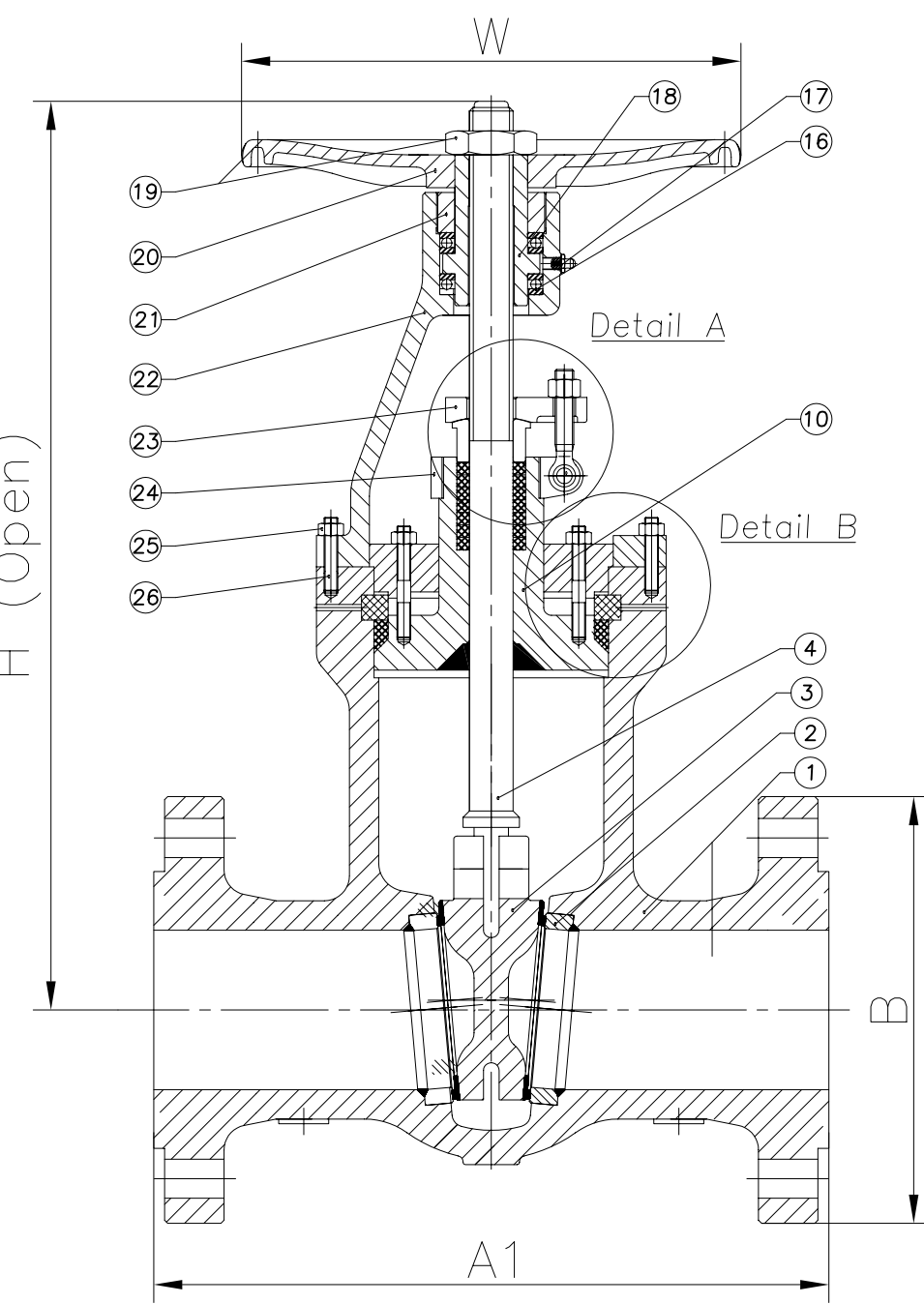

Detail B

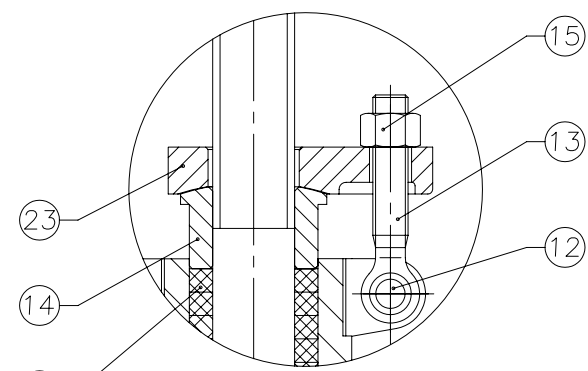

Detail A

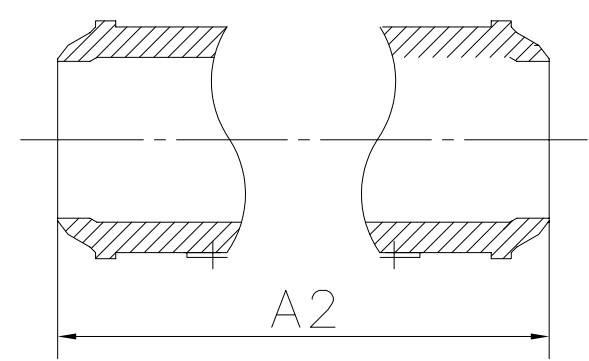

Butt-Weld Ends

BILL OF MATERIALS

NO.	Designation	QTY.	Material	Notes
26	Yoke Pan Bolt Nuts		ASTM A194 2HM	
25	Yoke Pan Bolts		ASTM A193 B7M	
24	Support	1	ASTM A216 WCB	
23	Gland Flange	1	ASTM A216 WCB	
22	Yoke	1	ASTM A216 WCB	
21	Retaining Nut	1	Carbon Steel	
20	Handwheel	1	Ductile Iron	
19	H.W.Lock Nut	1	Carbon Steel	
18	Stem Nut	1	AL-Bronze	
17	Lubricating Cup	1	Copper	
16	Axletree	2	Assembly	
15	Gland Nut	2	ASTM A194 2HM	
14	Gland	1	ASTM A182 F6	
13	Gland Eye Bolt	2	ASTM A193 B7M	
12	Pin	2	Carbon Steel	
11	Packing	7	Flexible Graphite	
10	Bonnet	1	ASTM A216 WCB	
9	Bonnet Flange	1	ASTM A216 WCB	
8	Gasket	1	304+Graphite	
7	Packing	1	Flexible Graphite	
6	Bonnet Nut		ASTM A194 2HM	
5	Bonnet Bolt		ASTM A193 B7M	
4	Stem	1	ASTM A182 F6	
3	Wedge	1	ASTM A216 WCB+STL	
2	Seat	2	ASTM A182 F6+STL	
1	Body	1	ASTM A216 WCB	

Size	A1	A2	B	H (Open)
2	368	216	216	397
3	470	305	267	635
4	546	406	311	676
6	705	559	394	1083
8	832	711	483	1197
10	991	864	585	1367
12	1130	991	675	1681
14	1257	1067	750	1684
16	1384	1194	825	2003
18	1537	1092	915	2264

ENGINEERING DATA

DESIGN CODE	API 600/ANSI B16.34	TEST PRESSURES		
FACE TO FACE DIMENSIONS	ASME B16.10	BODY	382.95	Barg
ENDS FLANGES DIMENSIONS	ASME B16.5	SEAT	280.83	Barg
TESTING CODE	API 598	BACKSEAT	280.83	Barg
		AIR - SEAT	6.0	Barg

REV	DATE	DESCRIPTION	BY	CHK	APP	SCALE:		
						DRAWN	DM	DATE
						CHECKED	SMN	DATE
						APPROVED	AW	DATE

DRAWING TITLE:  
API CAST STEEL CLASS 1500  
PRESSURE-SEAL BONNET, RF, GATE VALVES

CLIENT:

VENDOR PO REF:

EVC REF:

CAD. No. | DRAWING NUMBER: 120037 | REV

AREA No. | FACILITY | TYPE | SEQ. No. | SHT. No.

1 | 2 | 3 | 4 | 5 | 6 | 7 | 8

All drawings are subject to copyright, reproduction only with express permission of Edmund Valve Company (1965) Ltd. Subject to updating and revision. MATERIALS TO NACE MR0175 LATEST EDITION (WETTED PARTS).