

Detail B

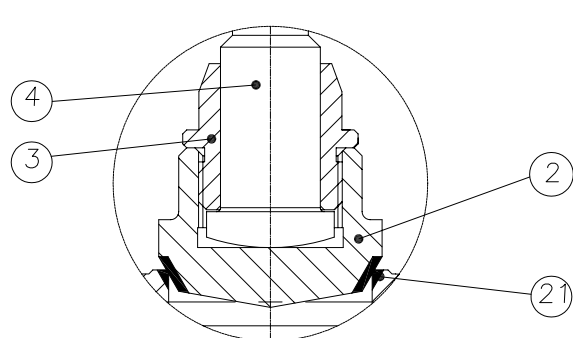

Detail A

BILL OF MATERIALS				
NO.	DESIGNATION	QTY	MATERIAL	NOTES
1	BODY	1	ASTM A216 WCB	
2	DISC	1	A216 WCB+13Cr.	
3	DISC NUT	1	ASTM A276 F6	
4	STEM	1	A182 F6a	
5	GASKET	1	304+GRAPHITE	
6	BACKSEAT BUSHING	1	A182 F6	
7	BONNET	1	ASTM A216 WCB	
8	BONNET BOLTS		ASTM A193 B7	
9	BONNET NUTS		ASTM A194 2H	
10	STEM PACKING	7	BRAIDED GRAPHITE	
11	PIN	2	CARBON STEEL	
12	GLAND EYE BOLTS	2	ASTM A193 B7	
13	GLAND	1	A182 F6	
14	GLAND FLANGE	1	ASTM A216 WCB	
15	WASHER	2	CARBON STEEL	
16	EYE BOLT NUTS	2	ASTM A194 2H	
17	STEM NUT	1	DUCTILE IRON	
18	HANDWHEEL	1	DUCTILE IRON	
19	HANDWHEEL WASHER	1	CARBON STEEL	
20	HANDWHEEL NUT	1	ASTM A194 2H	
21	SEAT	1	A216 WCB+STL	

ITEM NO.	N.B	DN	L	D	H(Open)
	2"	51	267	165	428
	3"	76	318	210	468
	4"	102	356	254	530
	6"	152	445	318	670
	8"	203	559	381	813
	10"	254	622	445	1075
	12"	305	711	521	1173
	14"	337	838	584	1377
	16"	387	863	648	1522
	18"	444	978	711	1514

ENGINEERING DATA

DESIGN CODE	BS1873/ANSI B16.34	TEST PRESSURES		
FACE TO FACE DIMENSIONS	ASME B16.10	BODY	76.65	Barg
ENDS FLANGES DIMENSIONS	ASME B16.5	SEAT	56.21	Barg
TESTING CODE	API 598	BACKSEAT	56.21	Barg
		AIR - SEAT	6.0	Barg

REV	DATE	DESCRIPTION	BY	CHK	APP

SCALE:	
DRAWN	DATE
CHECKED	DATE
APPROVED	DATE

DRAWING TITLE:
CAST STEEL CLASS 300
BOLTED BONNET, RF, GLOBE VALVES

PROJECT:
PACKAGE:
VENDOR DOC.NO.:



CAD. No.	DRAWING NUMBER:	120062	REV
	AREA No.	FACILITY	TYPE
	SEQ. No.	SHT. No.	

All drawings are subject to copyright, reproduction only with express permission of Edmund Valve Company (1965) Ltd. Subject to updating and revision. MATERIALS TO NACE MR0175 LATEST EDITION (WETTED PARTS).