

All drawings are subject to copyright, reproduction only with express permission of Edmund Valve Company (1965) Ltd. Subject to updating and revision.

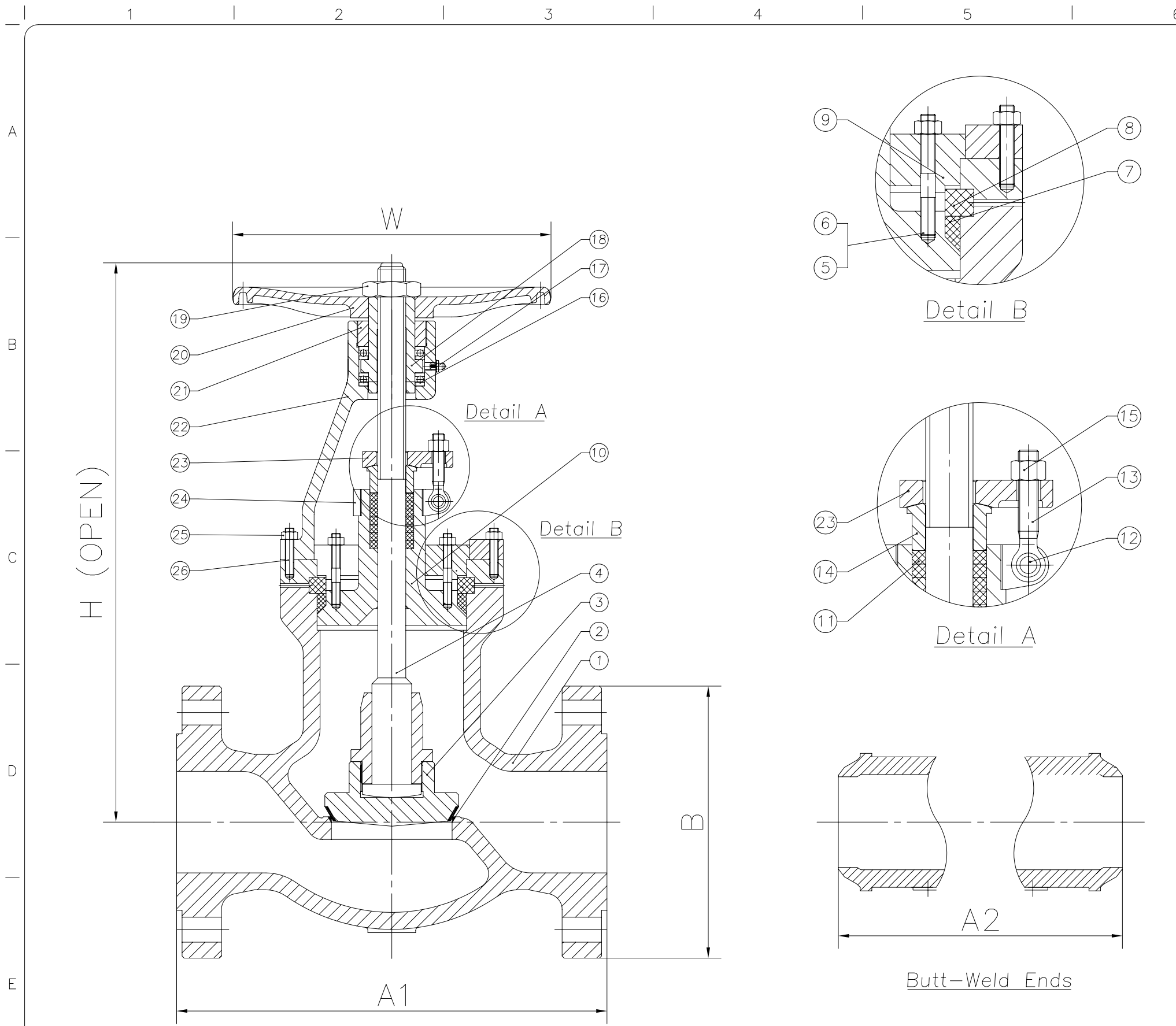

BILL OF MATERIALS				
NO.	Designation	QTY.	Material	Notes
26	Yoke Pan Bolt Nuts		ASTM A194 2HM	
25	Yoke Pan Bolts		ASTM A193 B7M	
24	Support	1	ASTM A216 WCB	
23	Gland Flange	1	ASTM A216 WCB	
22	Yoke	1	ASTM A216 WCB	
21	Retaining Nut	1	Carbon Steel	
20	Handwheel	1	Ductile Iron	
19	H.W.Lock Nut	1	Carbon Steel	
18	Stem Nut	1	AL-Bronze	
17	Lubricating Cup	1	Copper	
16	Axletree	2	Assembly	
15	Gland Nut	2	ASTM A194 2HM	
14	Gland	1	ASTM A182 F6	
13	Gland Eye Bolt	2	ASTM A193 B7M	
12	Pin	2	Carbon Steel	
11	Packing	7	Flexible Graphite	
10	Bonnet	1	ASTM A216 WCB	
9	Bonnet Flange	1	ASTM A216 WCB	
8	Gasket	1	304+Graphite	
7	Packing	1	Flexible Graphite	
6	Bonnet Nut		ASTM A194 2HM	
5	Bonnet Bolt		ASTM A193 B7M	
4	Stem	1	ASTM A182 F6a	
3	Disc	1	ASTM A216 WCB+13Cr	
2	Seat	2	ASTM A216 WCB+STL	
1	Body	1	ASTM A216 WCB	

Size	A1	A2	B	H (Open)
2	292	178	165	435
3	356	254	210	598
4	432	305	273	646
6	559	457	356	1011
8	660	660	419	1089
10	787	787	510	1289
12	838	838	559	1597
14	889	889	605	1597
16	991	990	685	1854

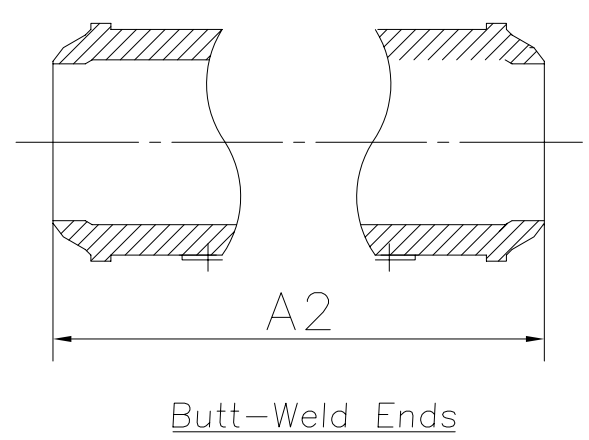

ENGINEERING DATA

DESIGN CODE	API 600/ANSI B16.34	TEST PRESSURES		
FACE TO FACE DIMENSIONS	ASME B16.10	BODY	153.15	Barg
ENDS FLANGES DIMENSIONS	ASME B16.5	SEAT	112.31	Barg
TESTING CODE	API 598	BACKSEAT	112.31	Barg
		AIR - SEAT	6.0	Barg

REV	DATE	DESCRIPTION	BY	CHK	APP	SCALE:		
						DRAWN	DM	DATE
						CHECKED	SMN	DATE
						APPROVED	AW	DATE

DRAWING TITLE:
API CAST STEEL CLASS 600
PRESSURE-SEAL BONNET, RF, GLOBE VALVES

CLIENT:

VENDOR PO REF:

EVC REF:

CAD. No. | DRAWING NUMBER: 120049 | REV

AREA No. | FACILITY | TYPE | SEQ. No. | SHT. No.