

BILL OF MATERIALS				
NO.	DESIGNATION	QTY	MATERIAL	NOTES
1	BODY	1	ASTM A216 WCB	
2	VALVE NUT	1	ASTM A194 2HM	
3	DISC NUT PIN	1	CARBON STEEL	
4	DISC WASHER	1	CARBON STEEL	
5	HINGE	1	ASTM A216 WCB	
6	DISC	1	ASTM A216 WCB+STL	
7	SEAT	1	ASTM A105+13%Cr	
8	HINGE PIN	1	ASTM A182 F6a	
9	BEARING BRACKET	1	ASTM A216 WCB	
10	BEARING BRACKET BOLT	1	ASTM A193 B7M	
11	SPRING WASHER	1	SPRING STEEL	
12	BONNET	1	ASTM A216 WCB	
13	GASKET	1	304+GRAPHITE	
14	SEPARATE RING	1	ASTM A276 410	
15	COVER	1	ASTM A216 WCB	
16	COVER BOLT		ASTM A193 B7M	
17	COVER NUT		ASTM A194 2HM	
18	STATIONARY RINGS	1	CARBON STEEL	
19	THRUST RING	1	ASTM A276 410	

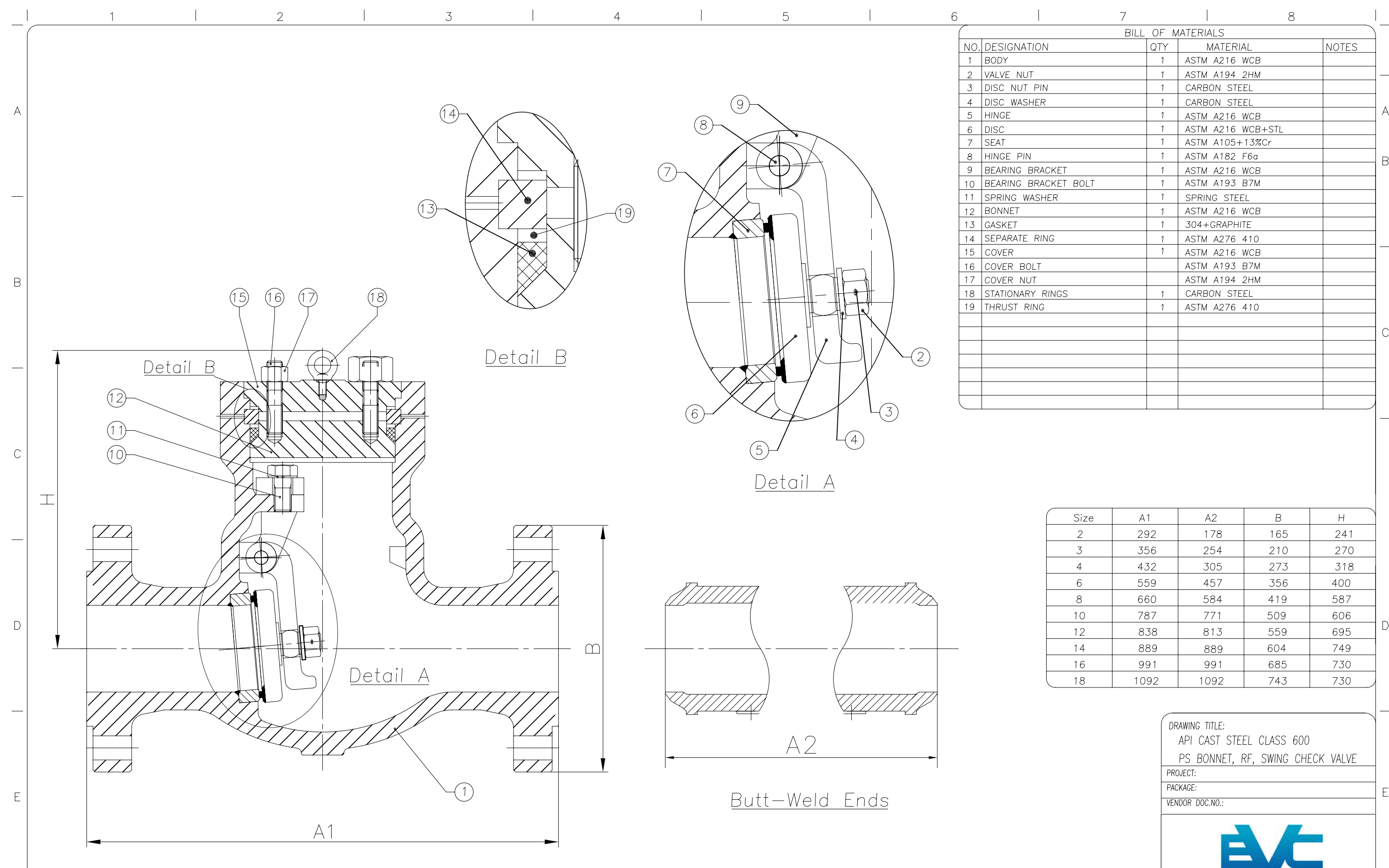

Size	A1	A2	B	H
2	292	178	165	241
3	356	254	210	270
4	432	305	273	318
6	559	457	356	400
8	660	584	419	587
10	787	771	509	606
12	838	813	559	695
14	889	889	604	749
16	991	991	685	730
18	1092	1092	743	730

ENGINEERING DATA

DESIGN CODE	BS 1868/ANSI B16.34	TEST PRESSURES		
FACE TO FACE DIMENSIONS	ASME B16.10	BODY	153.15	Barg
ENDS CONNECTION DIMENSIONS	ASME B16.25	SEAT	112.31	Barg
TESTING CODE	API 598	BACKSEAT	112.31	Barg
		AIR - SEAT	6.0	Barg

	BY	CHK	APP	SCALE:
				DRAWN DATE
				CHECKED DATE
				APPROVED DATE

DRAWING TITLE:
API CAST STEEL CLASS 600
PS BONNET, RF, SWING CHECK VALVE

PROJECT:

PACKAGE:

VENDOR DOC.NO.:

CAD. No. | DRAWING NUMBER: 120053 | REV

AREA No. | FACILITY | TYPE | SEQ. No. | SHT. No.

All drawings are subject to copyright, reproduction only with express permission of Edmund Valve Company (1965) Ltd. Subject to updating and revision. MATERIALS TO NACE MR0175 LATEST EDITION (WETTED PARTS).