

PRESSURE & TEMPERATURE TO ANSI B16.34; MATERIALS TO NACE MR-01-75 Latest Edition; HINGE/STOP PINS MUST BE VERTICAL FOR HORIZONTAL FLOW; LIFTING BOLTS SUPPLIED FOR VALVES 6" AND LARGER  
 All drawings are subject to copyright, reproduction only with express permission of Edmund Valve Company (1965) Ltd. Subject to updating and revision.

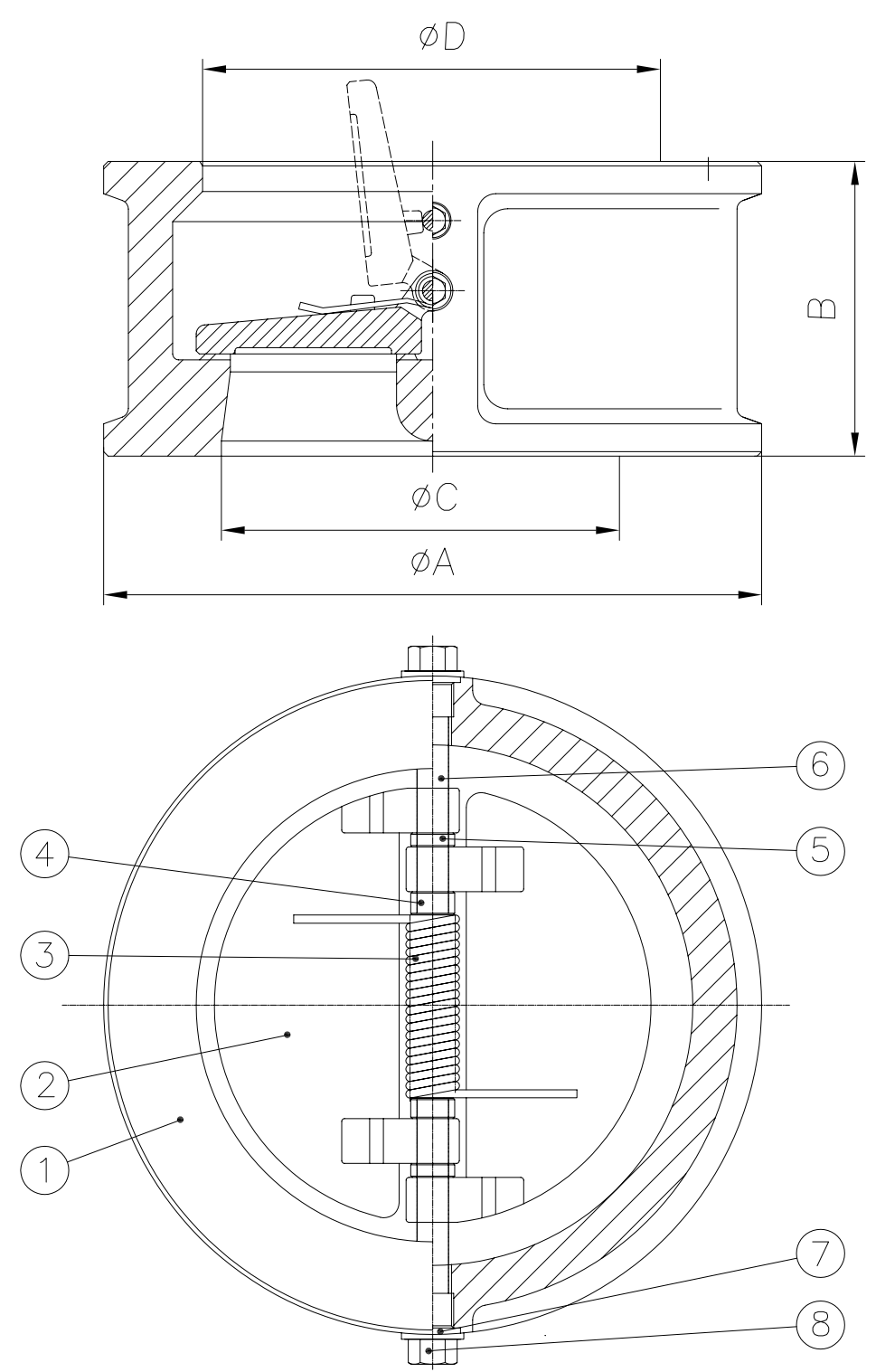

8	STOP PIN	A182 F316		
7	GASKET	A182 F316		
6	HINGE PIN	A182 F316		
5	BEARING	A182 F316		
4	SPRING PLATE	A182 F316		
3	SPRING	INCONEL X750		
2	DISC	ASTM A351 CF8M		
1	BODY	ASTM A351 CF8M	ASTM 216 WCB	
	BODY SEAT	AS BODY		1
	PLATE SEAT	AS PLATE		2
NO.	Name	Material		Notes

NOTES	
1.	Body Seat Overlay available - AISI 316 or Stellite 6
2.	Plate Seat Overlay available - AISI 316 or Stellite 6
3.	

Size Inches	Dimensions (mm)			
	A	B	C	D
2"	111.13	60.33	-	57.15
3"	149.23	73.03	50.80	86.87
4"	193.68	79.38	88.90	113.03
6"	266.70	136.53	88.90	165.61
8"	320.68	165.10	168.28	206.50
10"	400.05	212.73	200.03	260.35
12"	457.20	228.60	231.78	300.23
14"	492.13	273.05	231.78	338.84
16"	565.15	304.80	330.20	387.35
18"	612.78	361.95	330.20	438.15
20"	682.63	368.30	431.80	487.43
24"	790.58	438.15	509.60	578.61

ENGINEERING DATA

DESIGN CODE	API 594	TEST PRESSURES		
FACE TO FACE DIMENSIONS	API 594	BODY	153.1	Barg
ENDS FLANGES DIMENSIONS	ASME B16.5	SEAT	112.3	Barg
TESTING CODE	API 598			

REV	DATE	DESCRIPTION	BY	CHK	APP

SCALE:		
DRAWN	DM	DATE
CHECKED	SMN	DATE
APPROVED	AW	DATE

DRAWING TITLE:  
 API 594 CAST STEEL CLASS 600  
 WAFER, RF, CHECK VALVES

CLIENT: -  
 VENDOR PO REF: -  
 EVC REF: -

CAD. No. | DRAWING NUMBER: 120024 | REV  
 AREA No. | FACILITY | TYPE | SEQ. No. | SHT. No. | 01