

PRESSURE & TEMPERATURE TO ANSI B16.34; MATERIALS TO NACE MR-01-75 Latest Edition; HINGE/STOP PINS MUST BE VERTICAL FOR HORIZONTAL FLOW; LIFTING BOLTS SUPPLIED FOR VALVES 6" AND LARGER
 All drawings are subject to copyright, reproduction only with express permission of Edmund Valve Company (1965) Ltd. Subject to updating and revision.

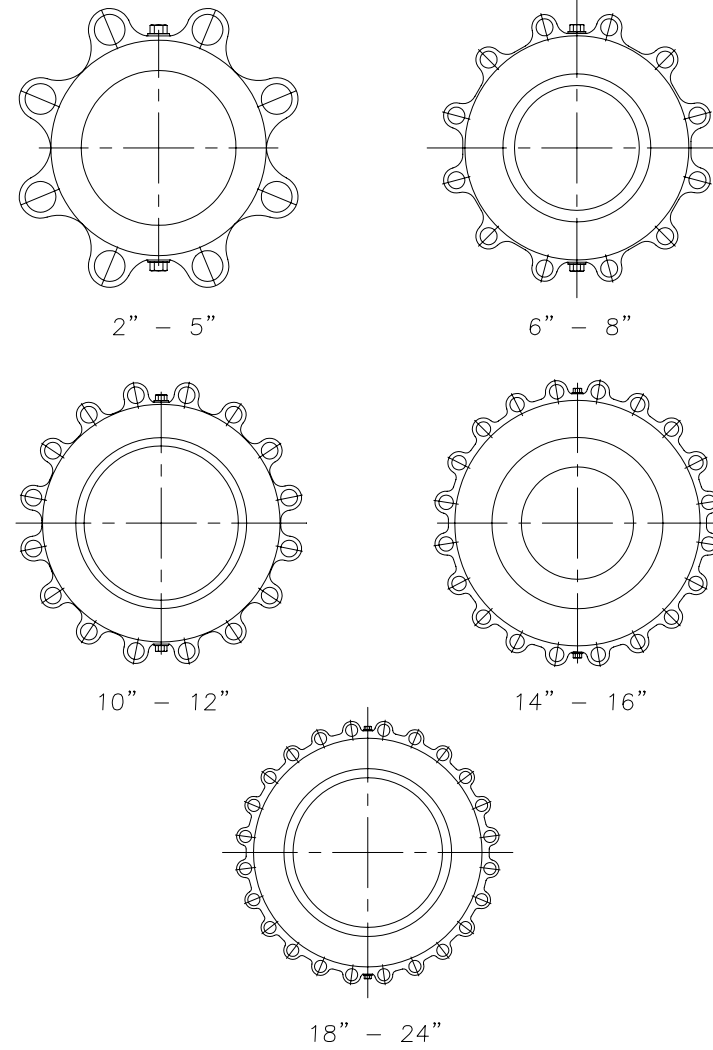
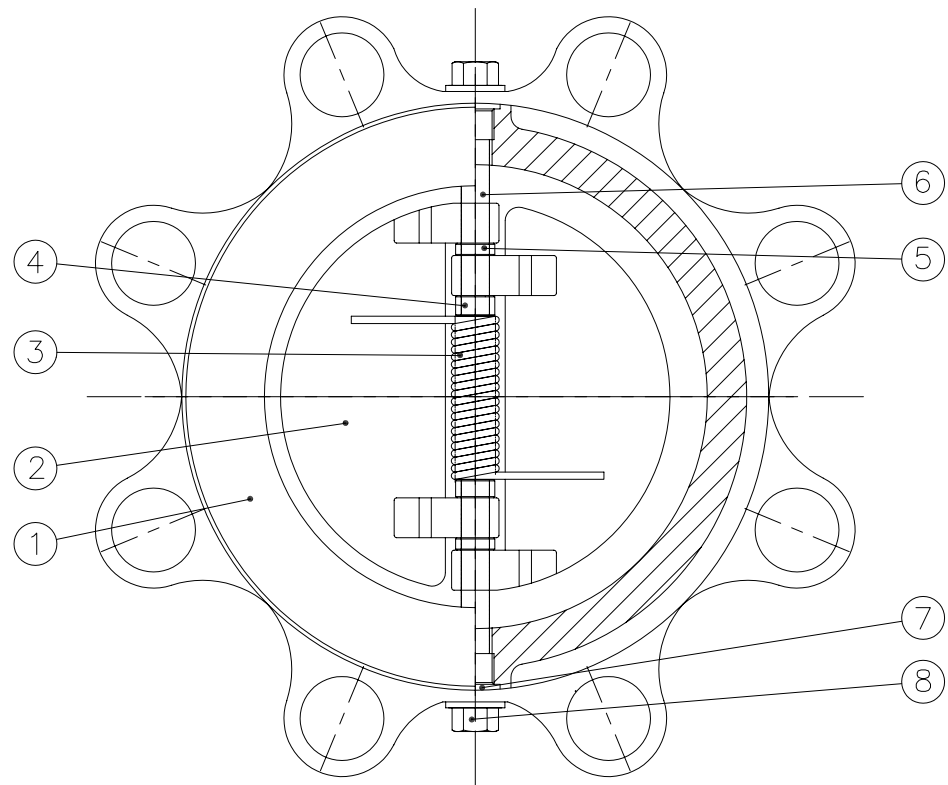
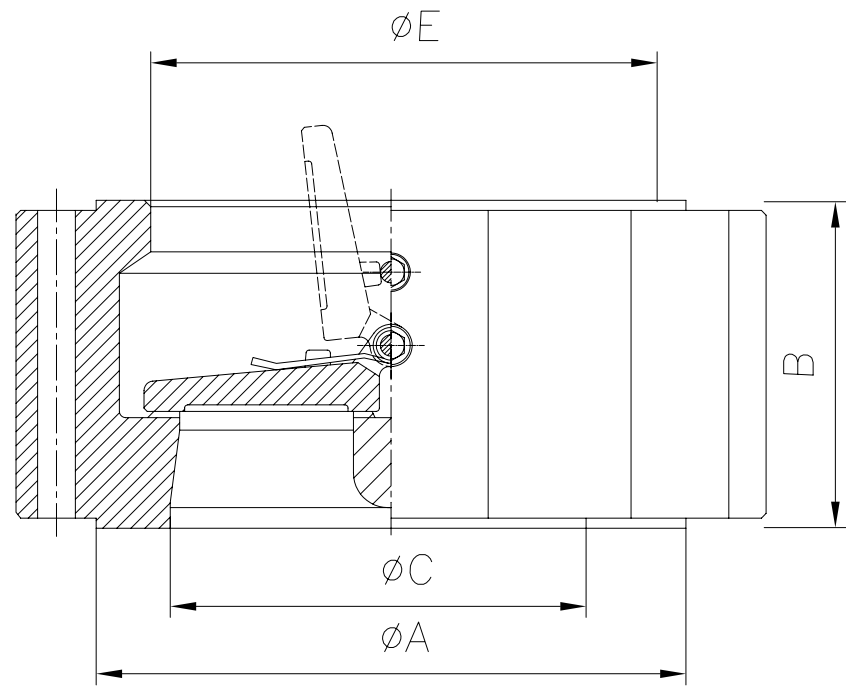

Hole Configuration

8	STOP PIN	A182 F316		
7	GASKET	A182 F316		
6	HINGE PIN	A182 F316		
5	BEARING	A182 F316		
4	SPRING PLATE	A182 F316		
3	SPRING	INCONEL X750		
2	DISC	ASTM A351 CF8M		
1	BODY	ASTM A351 CF8M	ASTM 216 WCB	
	BODY SEAT	AS BODY		1
	PLATE SEAT	AS PLATE		2
NO.	Name	Material		Notes

NOTES			
1.	Body Seat Overlay available -	AISI 316 or	Stellite 6
2.	Plate Seat Overlay available -	AISI 316 or	Stellite 6
3.			

Size Inches	Dimensions (mm)			
	A	B	C	D
2"	111.13	60.33	-	57.15
2.5"	130.18	66.68	-	74.68
3"	149.23	73.03	50.80	86.87
4"	180.98	73.03	88.90	113.03
5"	215.90	85.73	0.00	149.23
6"	250.83	98.43	139.70	165.61
8"	307.98	127.00	171.45	206.50
10"	361.95	146.05	234.95	260.35
12"	422.28	180.98	260.35	300.23
14"	485.78	222.25	285.75	338.84
16"	539.75	231.78	330.20	387.35
18"	596.90	263.53	390.53	438.15
20"	654.05	292.10	438.15	487.43
24"	774.70	317.50	523.88	578.61

ENGINEERING DATA

DESIGN CODE	API 594	TEST PRESSURES		
FACE TO FACE DIMENSIONS	API 594	BODY	76.6	Barg
ENDS FLANGES DIMENSIONS	ASME B16.5	SEAT	56.2	Barg
TESTING CODE	API 598			

REV	DATE	DESCRIPTION	BY	CHK	APP	SCALE:		
						DRAWN	DM	DATE
						CHECKED	SMN	DATE
						APPROVED	AW	DATE

DRAWING TITLE:
 API 594 CAST STEEL CLASS 300
 WAFER, RF, CHECK VALVES

CLIENT: -
 VENDOR PO REF: -
 EVC REF: -

CAD. No. | DRAWING NUMBER: 120029 | REV
 AREA No. | FACILITY | TYPE | SEQ. No. | SHT. No. | 01